



**Cambridge International Examinations**  
Cambridge International General Certificate of Secondary Education

CANDIDATE  
NAME

CENTRE  
NUMBER

--	--	--	--	--

CANDIDATE  
NUMBER

--	--	--	--

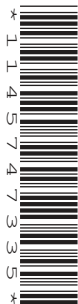

**CO-ORDINATED SCIENCES**

**0654/31**

Paper 3 (Core)

**October/November 2018**

**2 hours**

Candidates answer on the Question Paper.

No Additional Materials are required.

**READ THESE INSTRUCTIONS FIRST**

Write your Centre number, candidate number and name on all the work you hand in.

Write in dark blue or black pen.

You may use an HB pencil for any diagrams or graphs.

Do not use staples, paper clips, glue or correction fluid.

**DO NOT WRITE IN ANY BARCODES.**

Answer **all** questions.

Electronic calculators may be used.

You may lose marks if you do not show your working or if you do not use appropriate units.

A copy of the Periodic Table is printed on page 28.

At the end of the examination, fasten all your work securely together.

The number of marks is given in brackets [ ] at the end of each question or part question.

This document consists of **27** printed pages and **1** blank page.

1 Fig. 1.1 shows the different types of human teeth in the lower jaw.

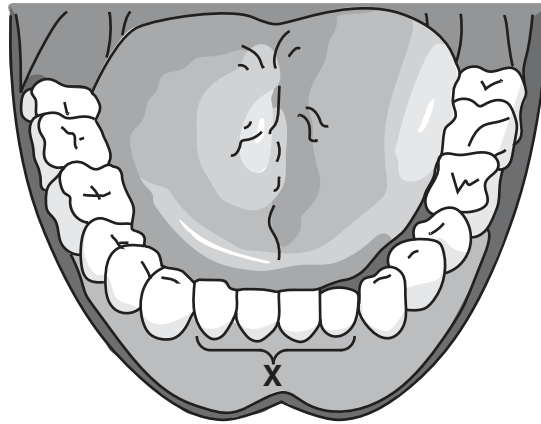

Fig. 1.1

(a) Identify the type of tooth labelled X in Fig. 1.1.

.....[1]

(b) Describe the function of each of the following types of teeth.

canine teeth .....

.....

molar teeth .....

.....

[2]

(c) Explain how the action of teeth aids digestion.

.....

.....

.....[2]

(d) Consuming too many sugary foods increases the risk of tooth decay.

Describe how eating sugary foods contributes to tooth decay.

.....

.....

.....

.....[3]

(e) Avoiding sugary foods is one way to decrease the risk of tooth decay.

Describe **one other** way to reduce tooth decay.

.....  
.....[1]

2 Calcium carbonate,  $\text{CaCO}_3$ , is the main compound in limestone.

(a) (i) State the number of different elements shown in the formula of calcium carbonate.

.....[1]

(ii) Calcium carbonate reacts with hydrochloric acid to produce calcium chloride and two other products.

Complete the **word** equation for this reaction.

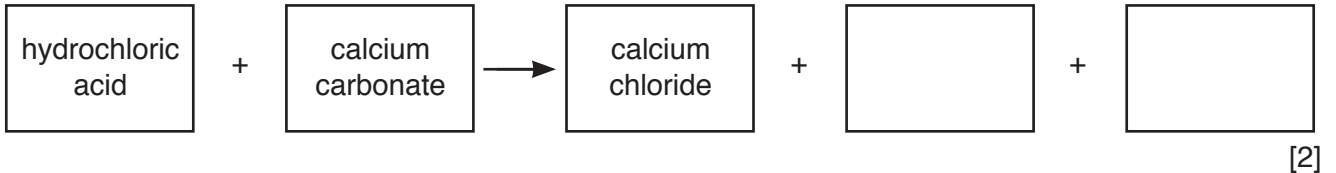

(iii) Describe **one** observation during the reaction in (a)(ii) that shows a chemical reaction is taking place.

.....[1]

(iv) Describe a chemical test, and its result, for chloride ( $\text{Cl}^-$ ) ions.

test .....

result .....

[2]

(b) A student heats 10.0g of limestone strongly for several minutes.

The limestone changes into a white solid **M**.

The mass of solid **M** is 5.6g.

(i) State the type of chemical reaction that occurs when limestone is heated strongly.

.....[1]

(ii) Explain why the mass of solid **M** is lower than that of the original piece of limestone.

.....

.....[1]

(iii) State the name of solid **M**.

.....[1]

(c) Describe why limestone is sometimes used to treat soil.

.....

.....[1]

- 3 (a) Table 3.1 shows the highest and lowest frequencies that four animals can hear.

**Table 3.1**

animal	highest frequency / Hz	lowest frequency / Hz
bat	110 000	2000
dog	50 000	50
dolphin	130 000	1000
elephant	12 000	5

- (i) State, in terms of waves, the meaning of the term *frequency*.

.....  
 ..... [1]

- (ii) State the range of audible frequencies for a human.

highest frequency ..... Hz

lowest frequency ..... Hz

[2]

- (iii) State which animal in Table 3.1 can hear a sound with the lowest pitch.

..... [1]

(b) Fig. 3.1 shows a bat locating a moth by emitting a pulse of ultrasound waves.

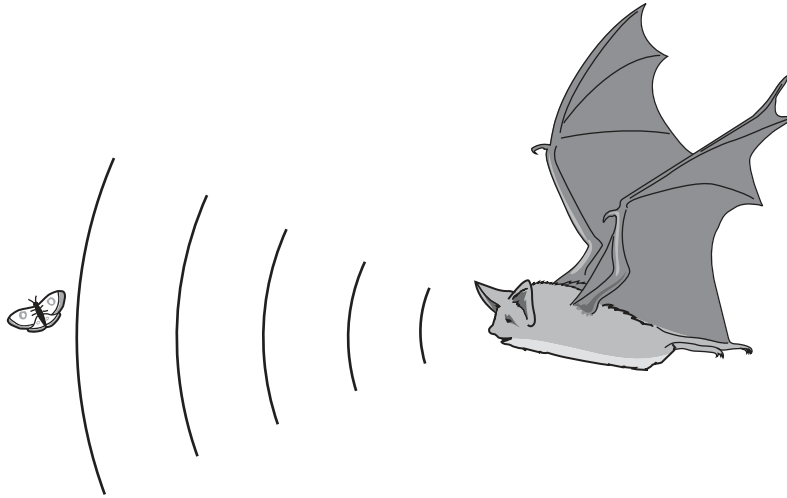

**Fig. 3.1**

The pulse of ultrasound takes 0.4 s to reach the moth and return to the bat after reflection.

The speed of ultrasound waves in air is 340 m/s.

(i) Calculate the total distance travelled by the ultrasound pulse.

State the formula you use and show your working.

formula

working

distance = .....m [2]

(ii) Use your answer to (b)(i) to calculate the distance between the moth and the bat.

distance = .....m [1]

(c) Some insects are attracted to wind turbines.

Bats and birds that are chasing these insects are being killed after flying into wind turbines.

(i) State **two other** disadvantages of using wind turbines to generate electricity.

1 .....

.....

2 .....

.....

[2]

(ii) Wind is one example of a renewable energy source.

State **one other** renewable energy source.

.....[1]

- 4 (a) Use words or phrases from the list to complete the definition of the term *transpiration*.

Each word or phrase may be used once, more than once or not at all.

**boiling**

**chlorophyll**

**chloroplast**

**evaporation**

**mesophyll**

**respiration**

**root hair**

**stomata**

Transpiration is defined as the ..... of water at the surfaces of the ..... cells followed by loss of water vapour from plant leaves through the .....

[3]

- (b) Two leaves of similar size are removed from the same plant. They are kept at different temperatures and their masses are recorded for six hours. All other variables are kept the same.

- Leaf **A** is kept at 18°C.
- Leaf **B** is kept at 35°C.

Fig. 4.1 shows a graph of the results.

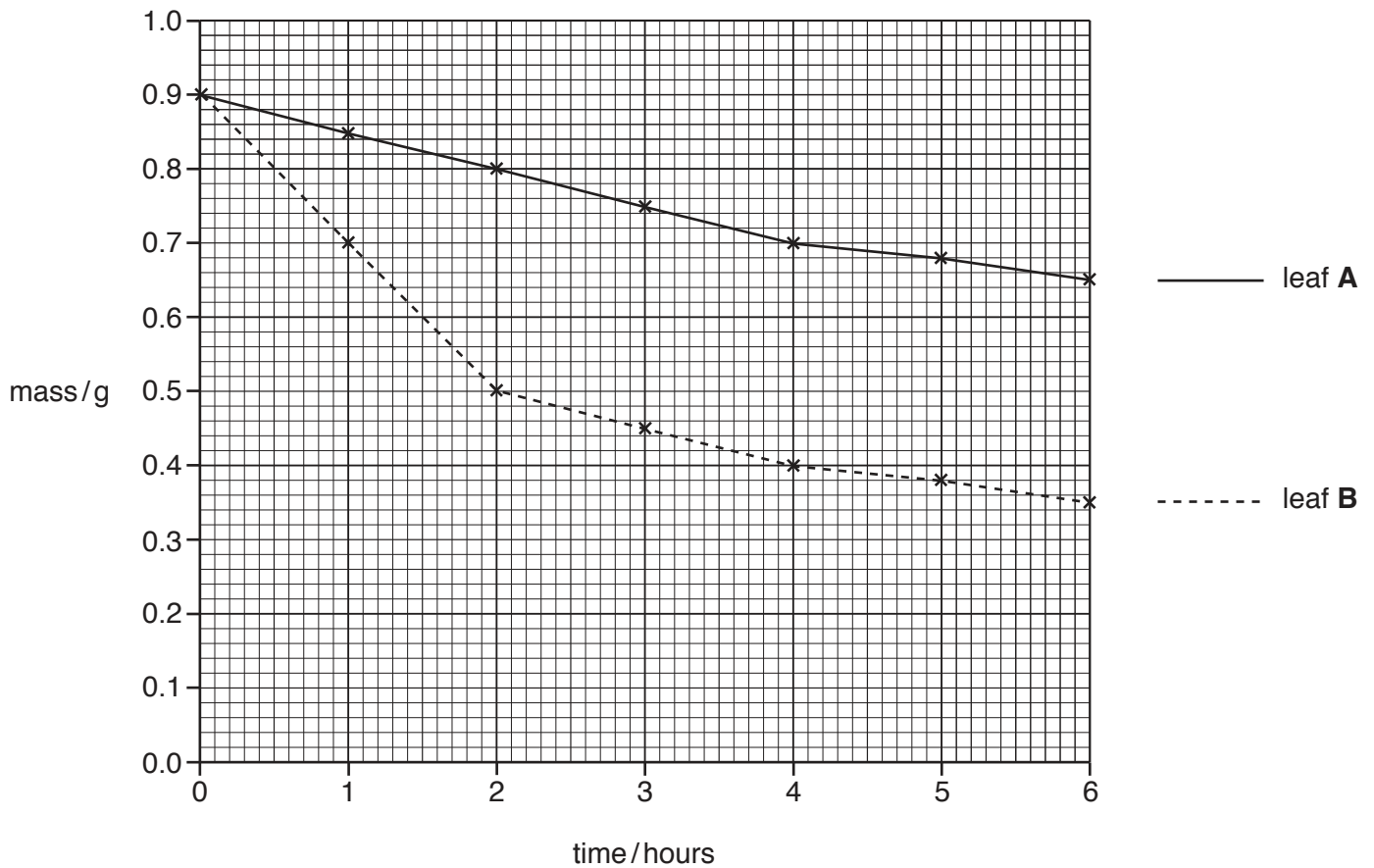

**Fig. 4.1**



- (i) Using values from the graph, calculate the mass **lost** by leaf **B** during the six hours.  
Show your working.

.....g [2]

- (ii) Explain why leaf **B** lost more mass than leaf **A**.

.....  
.....  
.....[2]

- (c) Describe how water moves from the soil to the cells in the leaves.

.....  
.....  
.....  
.....[3]

5 Group VII of the Periodic Table contains reactive non-metallic elements called the halogens.

A copy of the Periodic Table is shown on page 28.

(a) Describe the trend in physical state of the elements chlorine, bromine and iodine at room temperature.

.....  
 ..... [1]

(b) (i) The mass number of a chlorine atom is 35.

State the number of protons and of neutrons in this chlorine atom.

protons .....

neutrons ..... [1]

(ii) Name the part of an atom that contains the protons and neutrons.

..... [1]

(c) Sodium chloride,  $\text{NaCl}$ , and chlorine oxide,  $\text{Cl}_2\text{O}$ , are compounds of chlorine.

(i) State the type of chemical bonding in

sodium chloride, .....

chlorine oxide. .... [2]

(ii) Describe, in terms of electrons, how sodium atoms and chlorine atoms change when they react together.

sodium atoms .....

.....

chlorine atoms .....

..... [2]

(d) State which halogen, chlorine or iodine, reacts with aqueous sodium bromide to release bromine.

Explain your answer.

halogen .....

explanation .....

..... [1]

- (e) Fig. 5.1 shows the apparatus that is used for the electrolysis of copper chloride solution, using inert electrodes.

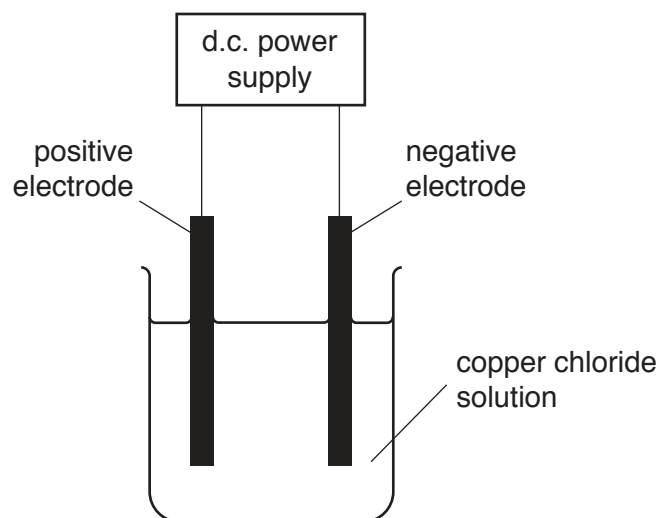

Fig. 5.1

Describe the appearance of the products at the positive electrode and the negative electrode.

positive electrode .....

negative electrode .....

[2]

6 (a) A bus gets very hot as it travels on a sunny day.

(i) State the method of thermal energy transfer between the Sun and the Earth.

.....[1]

(ii) Name the main part of the electromagnetic spectrum involved in the energy transfer stated in (a)(i).

.....[1]

(iii) Fig. 6.1 shows an incomplete electromagnetic spectrum.

On Fig. 6.1, label the part of the electromagnetic spectrum named in (a)(ii).

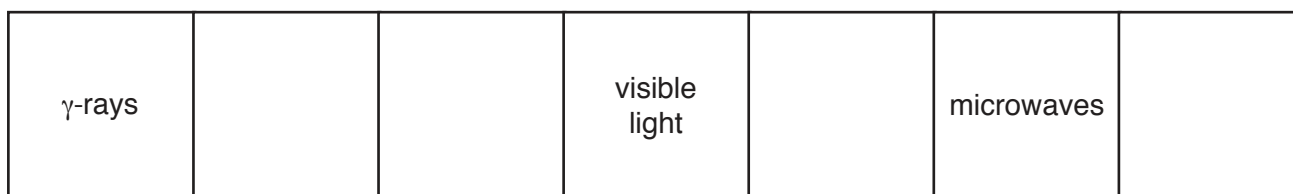

Fig. 6.1

[1]

(b) The air in the tyres of the bus also gets hot. The pressure of the air in the tyres increases.

(i) Describe, in terms of moving molecules, how the air inside a tyre exerts a pressure on the tyre wall.

.....  
 .....[1]

(ii) Explain, in terms of molecules, why the pressure of the air in the tyres increases as the air gets hot.

.....  
 .....  
 .....  
 .....  
 .....  
 .....[2]

(c) At night, the bus lamps are switched on.

Fig. 6.2 shows a circuit used for the lamps on the bus.

There are three switches, **A**, **B** and **C**, in the circuit.

There is a current of 0.5A in each sidelamp when lit.

There is a current of 6.0A in each headlamp when lit.

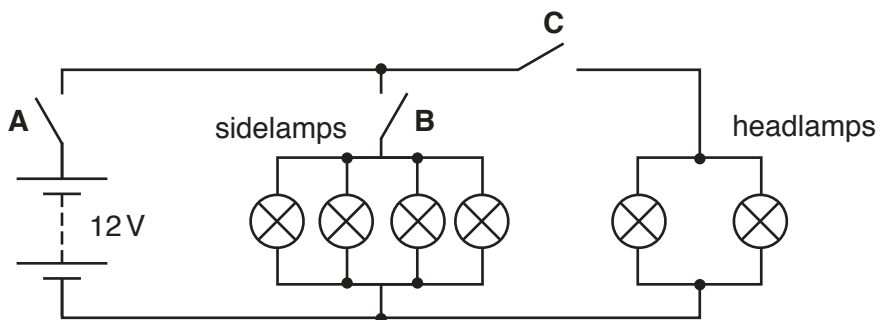

Fig. 6.2

(i) State which switch or switches must be closed for **only** the sidelamps to light up.

..... [1]

(ii) State which switch or switches must be closed for **only** the headlamps to light up.

..... [1]

(iii) Calculate the resistance of one of the sidelamps.

State the formula you use and show your working.

formula

working

resistance = .....  $\Omega$  [2]

(iv) The resistance of each headlamp is  $2.0\Omega$ .

From the list of resistance values, choose the correct value for the combined resistance of the two headlamps in parallel.

- 0.5  $\Omega$**       **1.0  $\Omega$**       **2.0  $\Omega$**       **4.0  $\Omega$**

resistance = .....  $\Omega$  [1]



7 Fig. 7.1 shows a diagram of the gas exchange system.

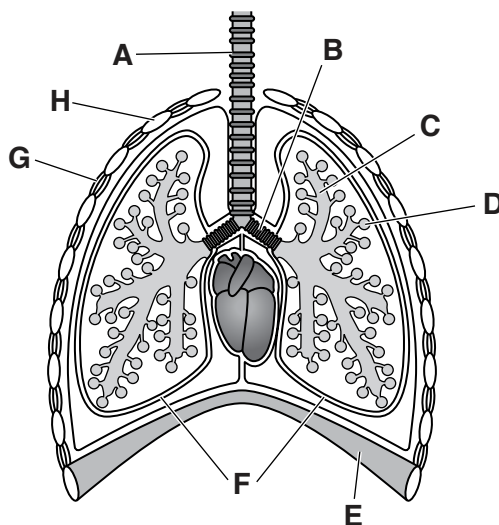

Fig. 7.1

(a) (i) Use Fig. 7.1 to state the letter that represents

an alveolus, .....

the diaphragm, .....

the trachea. ....

[3]

(ii) Draw an arrow to show the direction of the air entering the gas exchange system shown in Fig. 7.1.

[1]

(b) The breathing rate of a person changes depending on the activity the body is doing.

A list of different activities is shown.

- carrying a heavy load
- reading
- running a marathon
- sleeping
- talking
- watching television

State the **two** activities from the list that would cause the largest increase in breathing rate.

1 .....

2 .....

[2]

- 8 Table 8.1 shows the percentage composition by mass of an alloy of iron.

**Table 8.1**

element	symbol	percentage by mass in the alloy
carbon	C	1.0
chromium	Cr	4.0
iron	Fe	
molybdenum	Mo	8.8
tungsten	W	1.7
vanadium	V	2.0

- (a) (i) Calculate the percentage by mass of iron in the alloy.

Show your working.

percentage of iron = .....% [2]

- (ii) Iron is in the fourth period of the Periodic Table. The Periodic Table is shown on page 28.

Identify the **two other** elements in the alloy that are in the same period as iron.

1 .....

2 .....

[1]

- (iii) Name the collection of metals in the fourth period that contains iron.

.....[1]

- (b) Fig. 8.1 shows apparatus a student uses to investigate the rate of rusting.

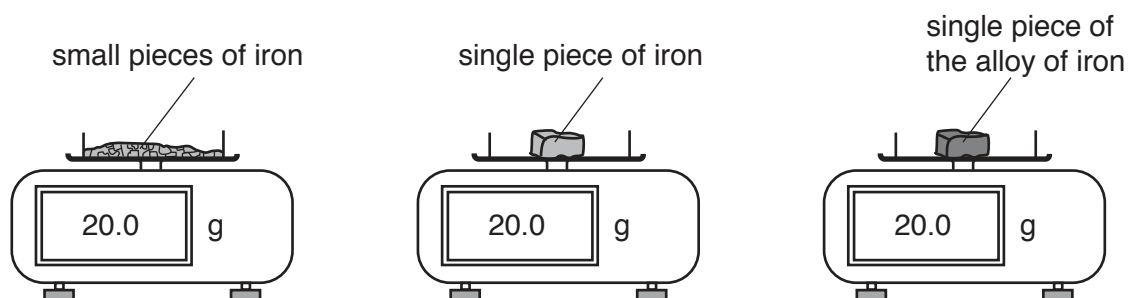

**Fig. 8.1**



She compares the rate of rusting of small pieces of iron, a single piece of iron and a single piece of the alloy of iron.

She places 20.0 g of each sample onto separate electronic balances.

She records the masses of the samples after ten days.

Table 8.2 shows some of her results.

**Table 8.2**

sample	mass at the start of the experiment/g	mass after ten days/g
small pieces of iron	20.0	21.2
single piece of iron	20.0	
single piece of the alloy of iron	20.0	20.0

- (i) Calculate the gain in mass of the small pieces of iron after ten days.

gain in mass = .....g [1]

- (ii) Calculate the average gain in mass per day of the small pieces of iron.

average gain in mass per day = .....g [1]

- (iii) Explain why the mass increases when iron rusts.

.....  
 .....  
 ..... [1]

- (iv) Suggest the mass of the single piece of iron after ten days.

..... [1]

9 A list of materials is shown.

**copper**                      **iron**                      **lead**                      **steel**                      **uranium**

(a) (i) State the names of the **two** materials from the list that are magnetic.

1 .....

2 .....

[1]

(ii) State **one** difference in the magnetic properties of the two materials named in (a)(i).

.....

.....[1]

(b) (i) State the name of the material from the list used to enclose radioactive samples and prevent the escape of ionising radiation.

.....[1]

(ii) State which radioactive emission,  $\alpha$ ,  $\beta$  or  $\gamma$ , is the most ionising.

.....[1]

(iii) Describe the effects of ionising radiation on the human body.

.....

.....

.....[2]

(c) A sheet of copper has a mass of 134.4g and a volume of 15.0cm<sup>3</sup>.

(i) Calculate the density of the sheet of copper.

State the formula you use and show your working. State the units of your answer.

formula

working

density = ..... units ..... [3]

(ii) The copper sheet is polished to form a mirror.

Fig. 9.1 shows an object reflected in the copper mirror.

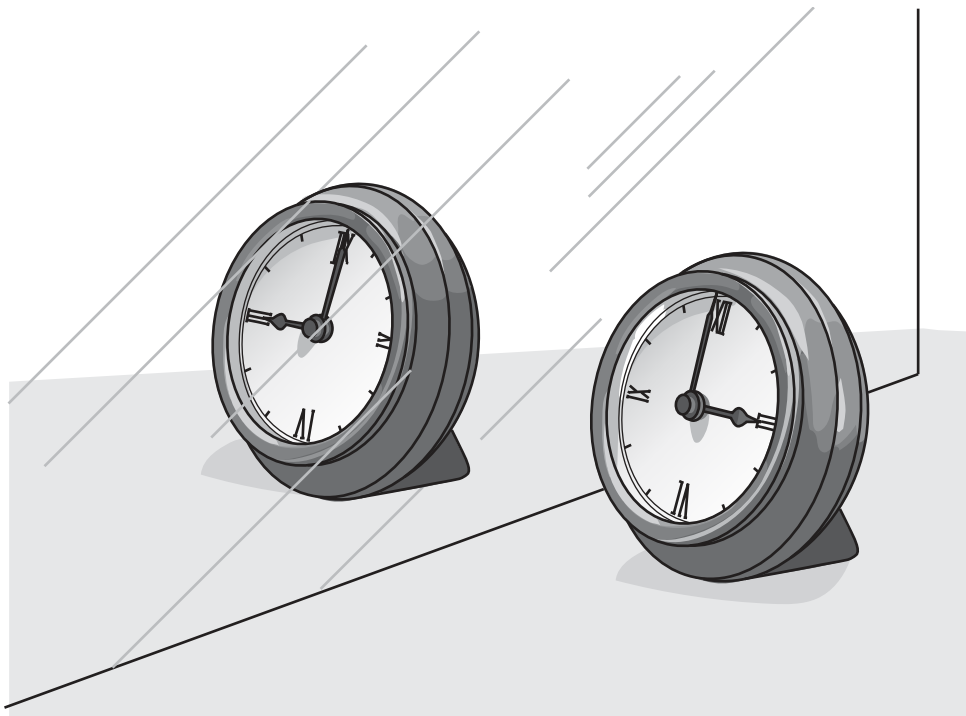

Fig. 9.1

The image in the mirror is the same size as the object.

Describe **two more** characteristics of an optical image seen in a plane mirror.

1 .....

2 .....

[2]

10 Fig. 10.1 shows a cross-section through a flower.

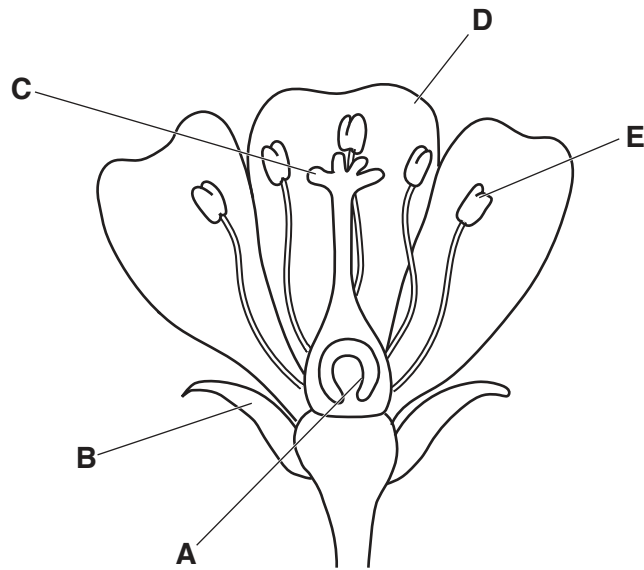

**Fig. 10.1**

(a) Table 10.1 shows information about some of the parts of the flower in Fig. 10.1.

Use Fig. 10.1 to complete Table 10.1.

**Table 10.1**

name of part	letter in Fig. 10.1	function
	<b>E</b>	
		attracting insects for pollination
	<b>B</b>	protecting the flower when in bud

[3]

(b) Pollination involves the transfer of pollen.

Place a tick (✓) next to **all** the ways in which pollen can be transferred.

- attached to the body of insects
- buried in the soil
- carried by the wind
- eaten by humans
- dispersed in animal faeces

[2]

(c) Flowers contain the organs of sexual reproduction in plants.

Plants can undergo asexual or sexual reproduction.

Describe **two** ways in which asexual reproduction differs from sexual reproduction.

- 1 .....
- .....
- 2 .....
- .....

[2]

11 Useful products containing hydrocarbons are obtained from petroleum.

(a) Name the process used to separate petroleum into useful products.

.....[1]

(b) One useful product obtained from petroleum is methane.

The complete combustion (burning) of methane causes an increase in temperature.

(i) State the term used to describe all chemical reactions that cause an increase in temperature.

.....[1]

(ii) State **two** compounds that are produced when methane burns completely.

1 .....

2 .....

[2]

(c) Some hydrocarbons are called alkanes.

Complete Table 11.1 about alkanes by stating the missing name and drawing the missing structure.

**Table 11.1**

name	structure
.....	$  \begin{array}{c}  \text{H} \\    \\  \text{H} - \text{C} - \text{H} \\    \\  \text{H}  \end{array}  $
ethane	

[2]

(d) Alkenes such as ethene,  $C_2H_4$ , are produced by strongly heating alkanes in the presence of a catalyst.

(i) Name this reaction which produces alkenes.

.....[1]

(ii) State what is meant by a *catalyst*.

.....  
.....[1]

(iii) Name the compound produced when ethene reacts with steam.

.....[1]

(e) Describe a test that is used to find out if a hydrocarbon is an alkane or an alkene.

test .....

.....

result for an alkane .....

.....

result for an alkene .....

.....

[3]

12 (a) Fig. 12.1 shows a car on a horizontal road. Two forces acting on the car are shown.

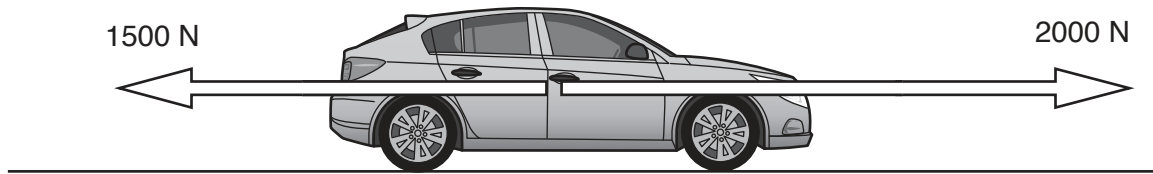

Fig. 12.1

Determine the magnitude and direction of the resultant force on the car.

magnitude ..... N

direction .....

[2]

(b) The fuel used in the car is a liquid. Exhaust gases from the car engine leave the car engine through an exhaust pipe made from solid steel.

Complete the sentences about solids, liquids and gases.

Use only the words **solid**, **liquid** or **gas**.

Each word may be used once, more than once or not at all.

In a ..... the particles are closest together.

The forces of attraction are weakest in a .....

In a ..... the particles can only vibrate but not move around. [2]

(c) A car engine transforms the chemical energy in gasoline (petrol) into thermal energy and sound energy.

State **two other** forms of energy gained by a car when it accelerates up a hill.

1 .....energy

2 .....energy

[2]



- (d) The red reflectors found on cars use total internal reflection to allow car drivers to see the back of another vehicle. They reflect the light from car headlamps. The reflectors are made of many tiny prisms.

Fig. 12.2 shows part of the path of a ray of light in a prism in the reflector.

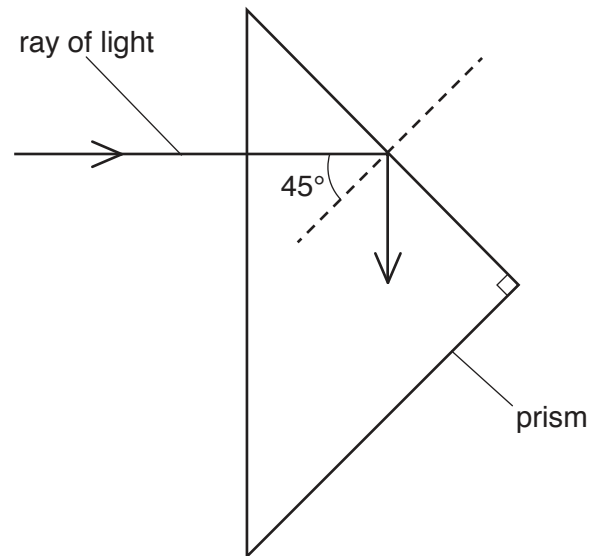

Fig. 12.2

On Fig. 12.2, complete the path of the ray of light to show how the ray emerges from the prism. [2]

13 Fig. 13.1 shows a simplified diagram of the carbon cycle.

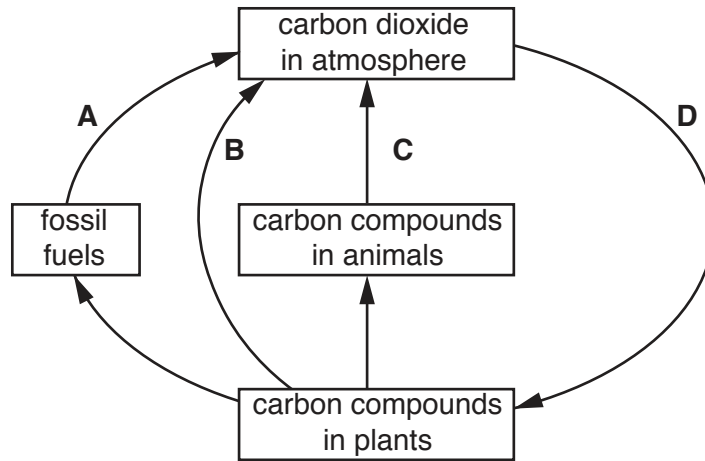

Fig. 13.1

(a) Name the process labelled **C** in Fig. 13.1.

.....[1]

(b) Describe how an increase in process **A** contributes to global warming.

.....  
 .....  
 .....[2]

(c) Explain why increasing the number of forested areas could reduce the rate of global warming.

.....  
 .....  
 .....[2]

- (d) The boxes on the left show some biological terms used when describing the organisms in a food chain.

The boxes on the right show the meanings of these terms.

Draw four lines to link each term with its meaning.

term	meaning
carnivore	an organism that gets its energy by feeding on other plants or animals
consumer	an animal that gets its energy by eating other animals
herbivore	an organism that makes its own organic nutrients using energy from the Sun
producer	an animal that gets its energy by eating plants

[3]

## The Periodic Table of Elements

Group																	
I	II											III	IV	V	VI	VII	VIII
3 <b>Li</b> lithium 7	4 <b>Be</b> beryllium 9	<b>Key</b> atomic number atomic symbol name relative atomic mass										5 <b>B</b> boron 11	6 <b>C</b> carbon 12	7 <b>N</b> nitrogen 14	8 <b>O</b> oxygen 16	9 <b>F</b> fluorine 19	10 <b>Ne</b> neon 20
11 <b>Na</b> sodium 23	12 <b>Mg</b> magnesium 24											13 <b>Al</b> aluminium 27	14 <b>Si</b> silicon 28	15 <b>P</b> phosphorus 31	16 <b>S</b> sulfur 32	17 <b>Cl</b> chlorine 35.5	18 <b>Ar</b> argon 40
19 <b>K</b> potassium 39	20 <b>Ca</b> calcium 40	21 <b>Sc</b> scandium 45	22 <b>Ti</b> titanium 48	23 <b>V</b> vanadium 51	24 <b>Cr</b> chromium 52	25 <b>Mn</b> manganese 55	26 <b>Fe</b> iron 56	27 <b>Co</b> cobalt 59	28 <b>Ni</b> nickel 59	29 <b>Cu</b> copper 64	30 <b>Zn</b> zinc 65	31 <b>Ga</b> gallium 70	32 <b>Ge</b> germanium 73	33 <b>As</b> arsenic 75	34 <b>Se</b> selenium 79	35 <b>Br</b> bromine 80	36 <b>Kr</b> krypton 84
37 <b>Rb</b> rubidium 85	38 <b>Sr</b> strontium 88	39 <b>Y</b> yttrium 89	40 <b>Zr</b> zirconium 91	41 <b>Nb</b> niobium 93	42 <b>Mo</b> molybdenum 96	43 <b>Tc</b> technetium —	44 <b>Ru</b> ruthenium 101	45 <b>Rh</b> rhodium 103	46 <b>Pd</b> palladium 106	47 <b>Ag</b> silver 108	48 <b>Cd</b> cadmium 112	49 <b>In</b> indium 115	50 <b>Sn</b> tin 119	51 <b>Sb</b> antimony 122	52 <b>Te</b> tellurium 128	53 <b>I</b> iodine 127	54 <b>Xe</b> xenon 131
55 <b>Cs</b> caesium 133	56 <b>Ba</b> barium 137	57–71 lanthanoids	72 <b>Hf</b> hafnium 178	73 <b>Ta</b> tantalum 181	74 <b>W</b> tungsten 184	75 <b>Re</b> rhenium 186	76 <b>Os</b> osmium 190	77 <b>Ir</b> iridium 192	78 <b>Pt</b> platinum 195	79 <b>Au</b> gold 197	80 <b>Hg</b> mercury 201	81 <b>Tl</b> thallium 204	82 <b>Pb</b> lead 207	83 <b>Bi</b> bismuth 209	84 <b>Po</b> polonium —	85 <b>At</b> astatine —	86 <b>Rn</b> radon —
87 <b>Fr</b> francium —	88 <b>Ra</b> radium —	89–103 actinoids	104 <b>Rf</b> rutherfordium —	105 <b>Db</b> dubnium —	106 <b>Sg</b> seaborgium —	107 <b>Bh</b> bohrium —	108 <b>Hs</b> hassium —	109 <b>Mt</b> meitnerium —	110 <b>Ds</b> darmstadtium —	111 <b>Rg</b> roentgenium —	112 <b>Cn</b> copernicium —	114 <b>Fl</b> flerovium —	116 <b>Lv</b> livermorium —	—	—	—	—

57 <b>La</b> lanthanum 139	58 <b>Ce</b> cerium 140	59 <b>Pr</b> praseodymium 141	60 <b>Nd</b> neodymium 144	61 <b>Pm</b> promethium —	62 <b>Sm</b> samarium 150	63 <b>Eu</b> europium 152	64 <b>Gd</b> gadolinium 157	65 <b>Tb</b> terbium 159	66 <b>Dy</b> dysprosium 163	67 <b>Ho</b> holmium 165	68 <b>Er</b> erbium 167	69 <b>Tm</b> thulium 169	70 <b>Yb</b> ytterbium 173	71 <b>Lu</b> lutetium 175
89 <b>Ac</b> actinium —	90 <b>Th</b> thorium 232	91 <b>Pa</b> protactinium 231	92 <b>U</b> uranium 238	93 <b>Np</b> neptunium —	94 <b>Pu</b> plutonium —	95 <b>Am</b> americium —	96 <b>Cm</b> curium —	97 <b>Bk</b> berkelium —	98 <b>Cf</b> californium —	99 <b>Es</b> einsteinium —	100 <b>Fm</b> fermium —	101 <b>Md</b> mendelevium —	102 <b>No</b> nobelium —	103 <b>Lr</b> lawrencium —

The volume of one mole of any gas is 24 dm<sup>3</sup> at room temperature and pressure (r.t.p.).